

# auto electrical parts

## Technical Information Sheet

### Part No. 0-295-50

Waterproof rear lamp, stop / tail / direction indicator / reflex reflector. Protected to IP67. Supplied with 12 volt bulbs and waterproof 4-pin plug. l 200 x w 60 x h 92mm. ECE approved.

#### Additional information

Can be mounted horizontal or vertical.



### Technical Drawing (not to scale)

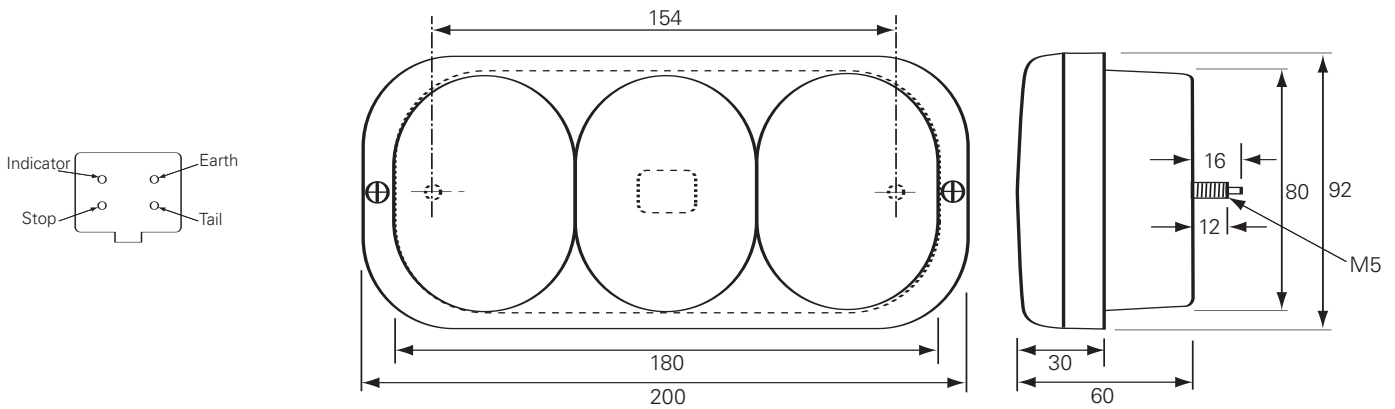

### Specification

Type	Rear combination lamp
Voltage	12 volt
Chambers	2
Bulbs	SBC 21/5W, SCC 21W
Lens material	Polycarbonate
Body material	Polypropolene
Connector	4-pin Deutsch
Weight	285g
Dimensions	l 200 x w 60 x h 92mm
Approvals	ECE
Protection	IP67

The information contained in this document is correct to the best of our knowledge at the time of printing. However, specifications may change at any time without notice.